



Intercom

## Desktop & Wall-Mount Intercoms

IP Enabled All-in-One Intercoms - Desk or Wall Mounting



### Description:

Digital Acoustics Desktop and Wall-Mount Intercoms are designed for indoor environments. These flexible intercoms provide intelligible, two-way audio for monitoring for remote stations, classrooms, guard desks, reception/entrance locations and more.

The **IP7-EDW-PoE** is simple to configure and install, and is ideal for new construction, upgrades of existing buildings or replacement of older analog systems. These intercoms are perfect when the deployment or configuration of a system requires frequent rearrangement such a classroom or office reassignment. Includes a wall-mount plate.

### Features:

- High-definition digital audio
- High-sensitivity microphone for two-way conversations
- Power-over-Ethernet (PoE)
- Multicast Protocol enables seamless, low-bandwidth audio
- Deploy with TalkMaster™ Focus, VoIP telephones, custom software, or third-party applications
- Single CAT 5/5e/6 cable installation
- Direct mode functionality supports remote contact closure

## Hardware Specifications:

**Network Protocols** - TCP, UDP, RTP, SIP, ICMP, IGMP Multicast  
**Network Interface** - 10/100 Base-T Ethernet, Auto-MDIX  
**Core Technology** - ICC-512 50 MIPS System on a Chip  
**IP Address Assignment** - Static, DHCP  
**Transport Bandwidth** - Nominal 64kbps  
**Audio Protocol** - 8-bit PCM/G.711 uLaw  
**Audio Latency** - <200ms Auto-Adaptive  
**Audio Line In/Out** - Nominal 1V p/p  
**Speaker Out** - 1 Watt  
**Microphone** - On-board Electret with software controlled AGC  
**Power (Nominal)** - 7.5 - 9VDC @ 5W  
**PoE Standard** - 802.3af  
**Diagnostics** - LED Status, Temperature and Power Monitoring  
**Programming** - Flash programmable via Ethernet  
**Fault-Management** - Advanced Fail-Forward™ fault detection  
**Temperature (°C)** -30~70 (Operating), -40~85C (Storage)  
**Size** - 5.3 x 4.0 x 1.35 in (98 x 91 x 35 mm)

### Connection Modes:

TalkMaster™ Focus Endpoint  
SIP 2.0 Endpoint  
Hybrid TalkMaster™ Focus/SIP 2.0 Endpoint  
Direct Mode  
Singlewire Informacast



### CONFIGURATIONS & Part Numbers

**IP7-EDW-PoE** - White, includes surface mount plate

**IP7-EDB-PoE** - Black, includes surface mount plate.

Limited quantities available!

### Desktop – IP7-EDx

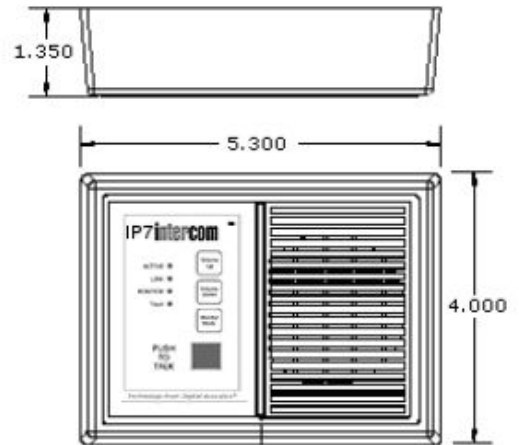

### Surface Mount – IP7-ESx

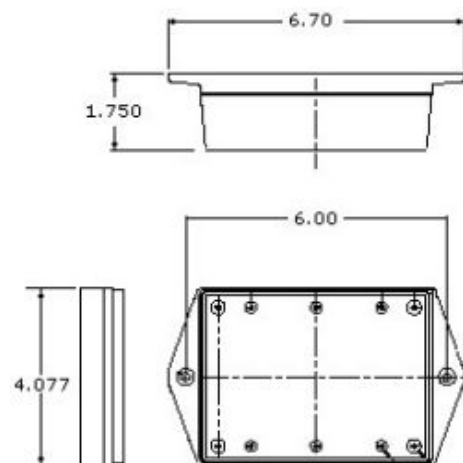

Visit [www.DigitalAcoustics.com](http://www.DigitalAcoustics.com) to learn about software products to complete your IP audio system.

